

JUNE. 15. 1998

Approved by: KyoYoung JIN



Checked by: Kim, MyeongKee



Issued by: JinBaek Song

J. B. SONG

# SPECIFICATION

MODEL: H210TC

Surface Acoustic Wave Filter

SAMSUNG ELECTRO-MECHANICS CO., LTD.

314. MAETAN-3DONG, PALDAL-KU

SUWON-SI, KYUNGKI-DO, KOREA

## 1. OUTLINE DRAWING AND DIMENSION

[Unit : mm]



TOP VIEW



SIDE VIEW

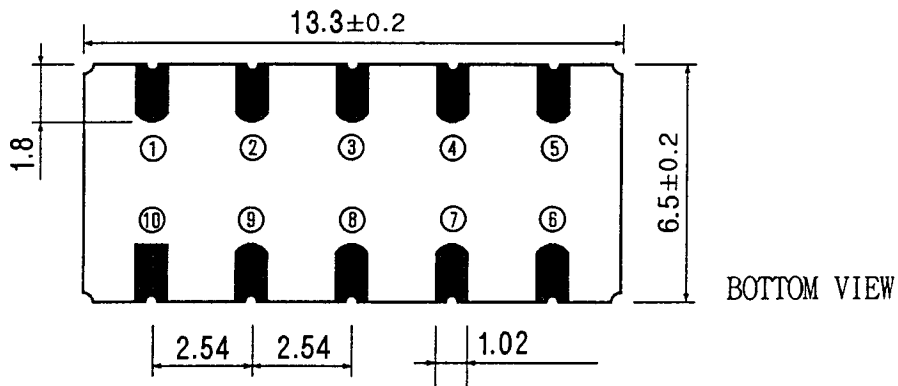

BOTTOM VIEW

No.	Function
⑩	Input
①	Input ground or balanced input
⑤	Output
⑥	Output ground or balanced output
②③④ ⑦⑧⑨	Case-ground

## 2. MARKING

# H210TC

## 8N

① Color : Black or Laser Marking

② Model No. : H210TC

③ Lot No. : 8N

- The first character '8' indicates the year of manufacturing

1998 ----- 8

1999 ----- 9

2000 ----- 0

- The second character 'N' indicates the month of manufacturing

January ----- 1

February ----- 2

: :

October ----- 0

November ----- N

December ----- D

## 3. PERFORMANCE

## 3-1. APPLICATION

Band-pass Filter for US PCS IF stage etc.

Center Frequency : 210.38 MHz

## 3-2. MAXIMUM RATING

Characteristics	Rating	Units
Maximum Input Power	20	dBm
Operating Temperature Range	-30 ~ +80	°C
Storage Temperature Range	-55 ~ +125	°C

## 3-3. ELECTRICAL CHARACTERISTICS

## 3-3-1. TABLE

Characteristics	Frequency	Specification
Nominal Center Frequency( $f_0$ )	210.38MHz	
Bandwidth at 5dB	$f_0$ Reference	$f_0 \pm 0.63\text{MHz}$ Min.
Bandwidth at 38dB	$f_0$ Reference	$f_0 \pm 1.25\text{MHz}$ Max.
Insertion Loss( $\alpha$ )	$f_0$	10.5dB Max..
Stop band Attenuation (Ref.: $\alpha$ )	130.00MHz ~ 209.13MHz 211.63MHz ~ 270.00MHz	40dB Min. 40dB Min.
Trap Rejection (Ref.: $\alpha$ )	$f_0 \pm 1.25\text{MHz}$	45dB Min
Amplitude Ripple	$f_0 \pm 0.3\text{MHz}$	1.2dB Max.
Phase Variation	$f_0 \pm 0.63\text{MHz}$	2.5° rms Max.
Terminating Impedance( $Z_0$ )	Input: 1000 ohms Matching Balanced Drive Output: 500 ohms Matching Balanced Drive	

## 3-3-2. GRAPH

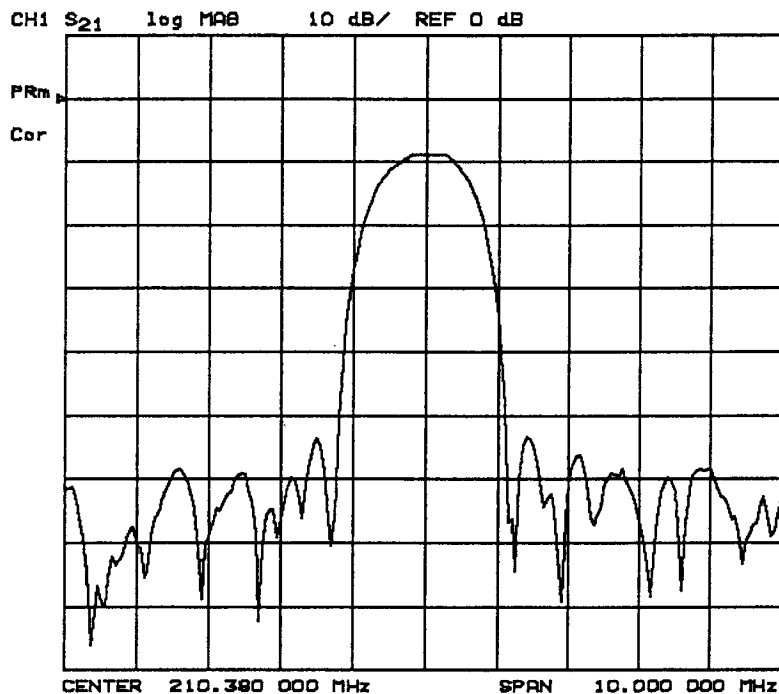

3-3-3. TEST FIXTURE

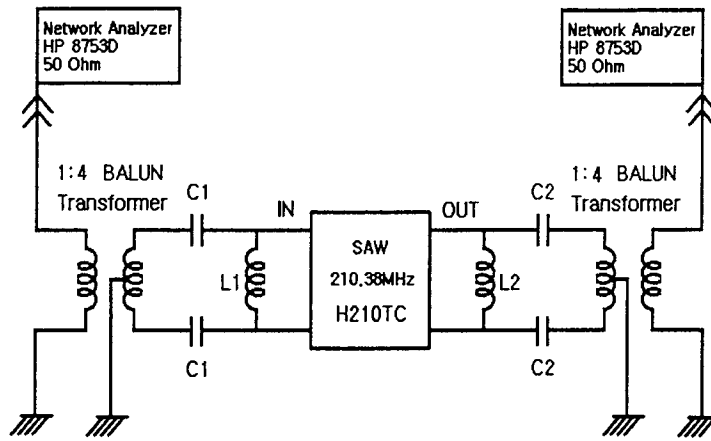

L1(nH)	C1(pF)	L2(nH)	C2(pF)
27 + tuning C	8	27 + tuning C	8

## 4. RELIABILITY

## 4-1. LIFE TEST

ITEM	TEST CONDITION	LIMIT
High Temperature Exposure	Ta = +85±2°C, 100h	After the test, specimen would be kept at room temperature for 2 hours. Specimen shall meet the electrical specification
Low Temperature Exposure	Ta = -55±2°C, 100h	
Moisture Resistance	Ta = +40±2°C, RH 90-95%, 250h	
Change due to Age	Ta = +85±2°C, 720h	

## 4-2. HEAT CYCLE, SOLDERING TEST

ITEM	TEST CONDITION	LIMIT
Temperature Cycle	-40°C, 30min ↔ 85°C, 30min 10 cycles	SAME as 4-1
Solderability	Immerse the sample in solder at 230±5°C for 5±1 sec.	More than 3/4 area of the pad should be covered with solder.
Resistance to Soldering Heat (Reflow)	Preheat : 180°C, 2 min. Reflow : 240°C, 10 sec.	SAME as 4-1

## 4-3. MECHANICAL TEST

ITEM	TEST CONDITION	LIMIT
Vibration	Amplitude=1.5mm, 10↔55Hz, sweep time=1min., 3directions for 2 hours	SAME as 4-1
Shock	Peak acceleration=1500G Duration=0.5msec., Wave form=half-sine pulse, 6 direction each 3 shocks.	

5. PACKING

5.1 Dimensions

- (1) Carrier Tape : Figure 1 (P.8/10)
- (2) Reel : Figure 2 (P.9/10)
- (3) The product shall be packed properly not to damaged during transportation and storage

5.2 Reeling Quantity

2,000 pcs/reel

5.3 Taping Structure

- (1) The tape shall be wound around the reel in direction shown below.

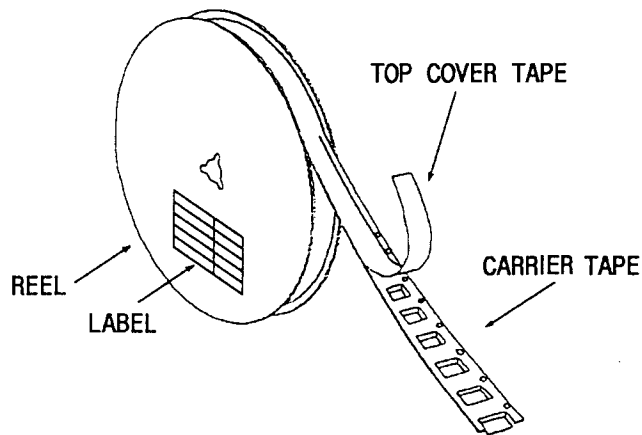

- (2) Label

Device Name	
User Product Name	
Quantity	
Lot No.	

- (3) Leader part and vacant position specifications.

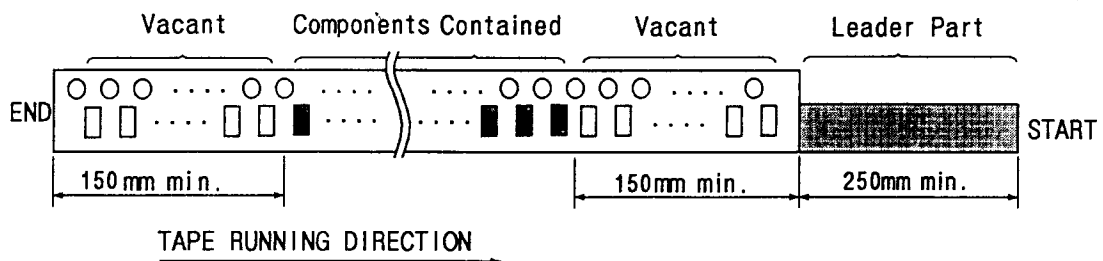

6. Tape Specifications

6.1 Tensile Strength of Carrier Tape : 4.4N/mm width

6.2 Top Cover Tape Adhesion(See the below figure)

- (1) pull of angle: 0-15 °
- (2) speed : 300mm/min.
- (3) force : 20-70g

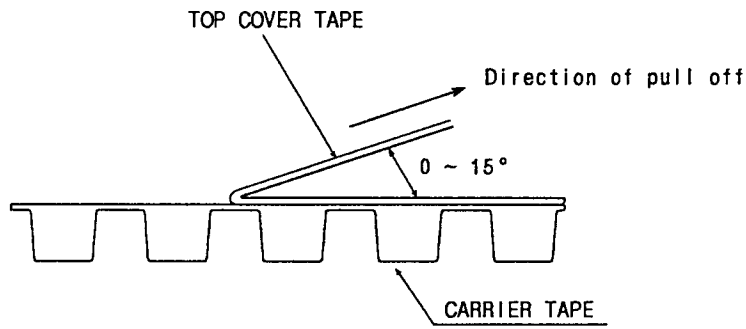

[Figure 1] Carrier Tape Dimensions

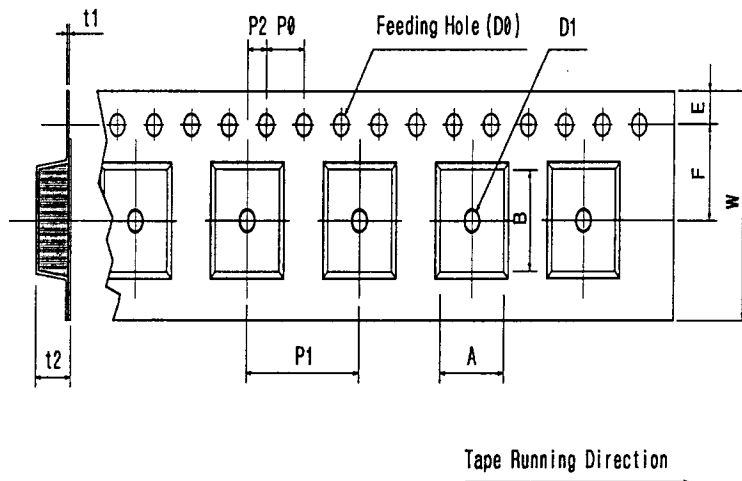

[Unit: mm]

W	F	E	P0	P1	P2	D0	D1	t1	t2	A	B
24.0	11.5	1.75	4.0	12.0	2.0	φ 1.5	φ 1.5	0.33	2.01	6.93	13.74
±0.3	±0.1	±0.1	±0.2	±0.1	±0.2	±0.1	±0.25	±0.03	±0.1	±0.2	±0.2



[Figure 2] Rec

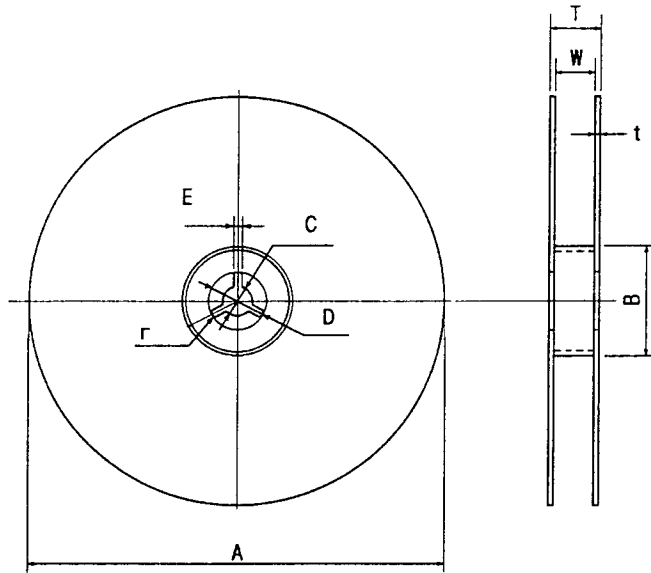

[Unit : mm]

A	B	C	D	E	W	t	T	r
$\varphi 328$	$\varphi 100$	$\varphi 13.8$	$\varphi 22.6$	2.0	24.4	2.5	26.9	1.0
$\pm 8.0$	$\pm 4.0$	$\pm 0.4$	$\pm 0.6$	$\pm 0.2$	+2,-0	$\pm 0.5$	$\pm 2.0$	$\pm 0.1$

[Figure 3] Part Direction

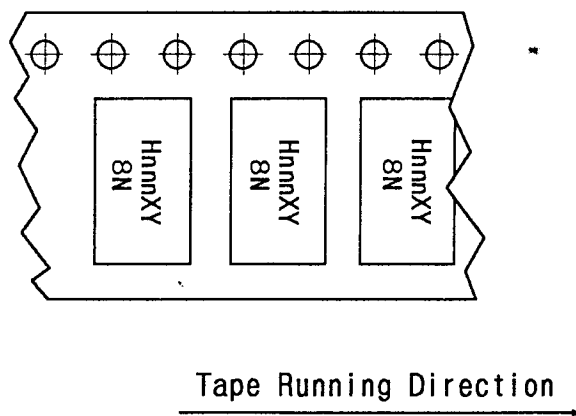

## 7. CAUTION

7-1. This device should not be used in any type of fluid such as water, oil, organic solvent, etc.

7-2. Ultrasonic cleaning shall be avoided.

7-3. This is an electrostatic sensitive device.  
Please avoid static voltage during operation and storage.

7-4. Sudden change of temperature shall be avoided, deterioration of the characteristics can occur.

## 8. REVISION

Date	Page	Revision	Reason